

S4S-Z365SP

41.8 kWm @ 2300 rpm | VARIABLE SPEED

MITSUBISHI DIESEL ENGINE

COMPACT AND RELIABLE

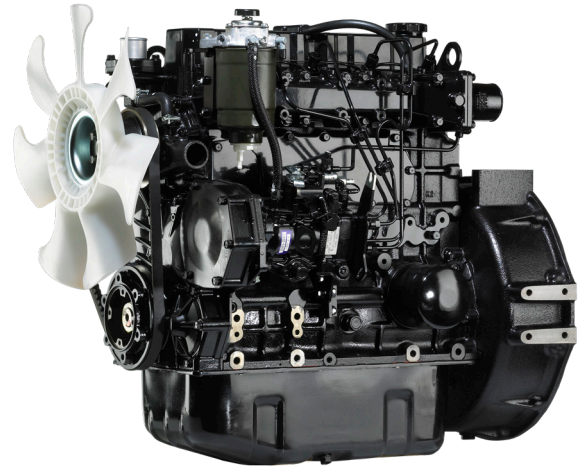

ENGINE DATA

Engine model	S4S-Z365SP
Engine type	4-stroke, diesel
Cylinder configuration	4 in-line
Bore x stroke (mm)	94 × 120
Total displacement (l)	3.331
Aspiration	natural
Dry weight (kg)	245
Emission	EU Stage IIIA

Cooling system	water-cooled, forced circulation by centrifugal pump with thermostat
Combustion system	indirect injection, swirl chamber type
Fuel injection system	pump-line-nozzle (rotary pump)
Electrical system (V / A)	12 / 50
Starting system (V / kW)	12 / 2.2
Rotation (ISO 1204)	counterclockwise
Flywheel and housing	semi: SAE 11.5" / SAE #3

RATING¹

	Gross		Net
	w/o fan	with fan	
Output (kWm)	41.8	40.5	
Output (bhp)	56.1	54.3	
Engine speed (rpm)	2300		

Gross

Fuel consumption 100% load (g/kWh) ²	255
Max. torque (Nm)	182
Side gear PTO (Nm)	39.2

¹ Rating definition according ISO3046, rating tolerance ±5% of nominal. ² Fuel consumption is based on ISO3046/1 with ±8% tolerance at 100% rated power.

PERFORMANCE CURVE

DIMENSIONS

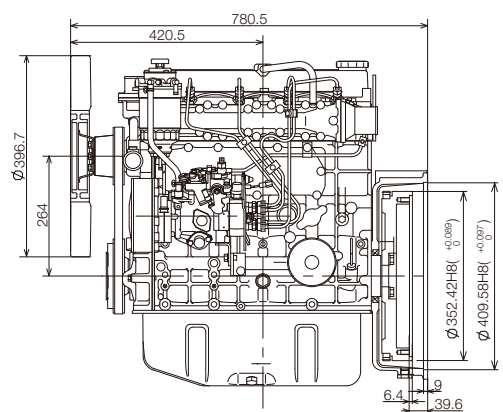
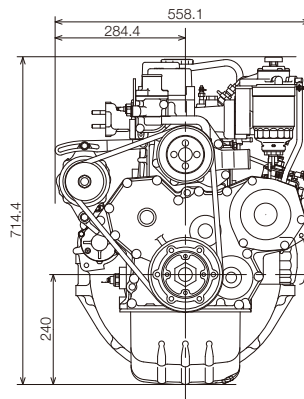
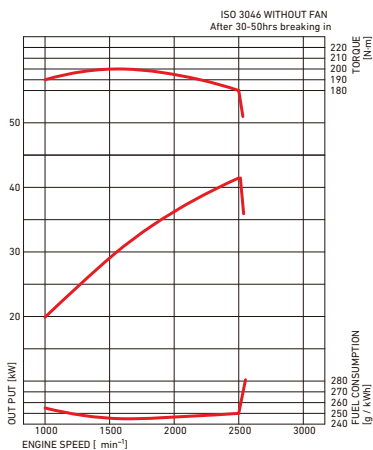

More information

Contact your local dealer for more information regarding Mitsubishi Diesel Engines and optional equipment or, visit www.mtee.eu/engines

MOVE THE WORLD FORWARD  **MITSUBISHI
HEAVY
INDUSTRIES
GROUP**